

WALL PANEL CONSTRUCTION TABLE

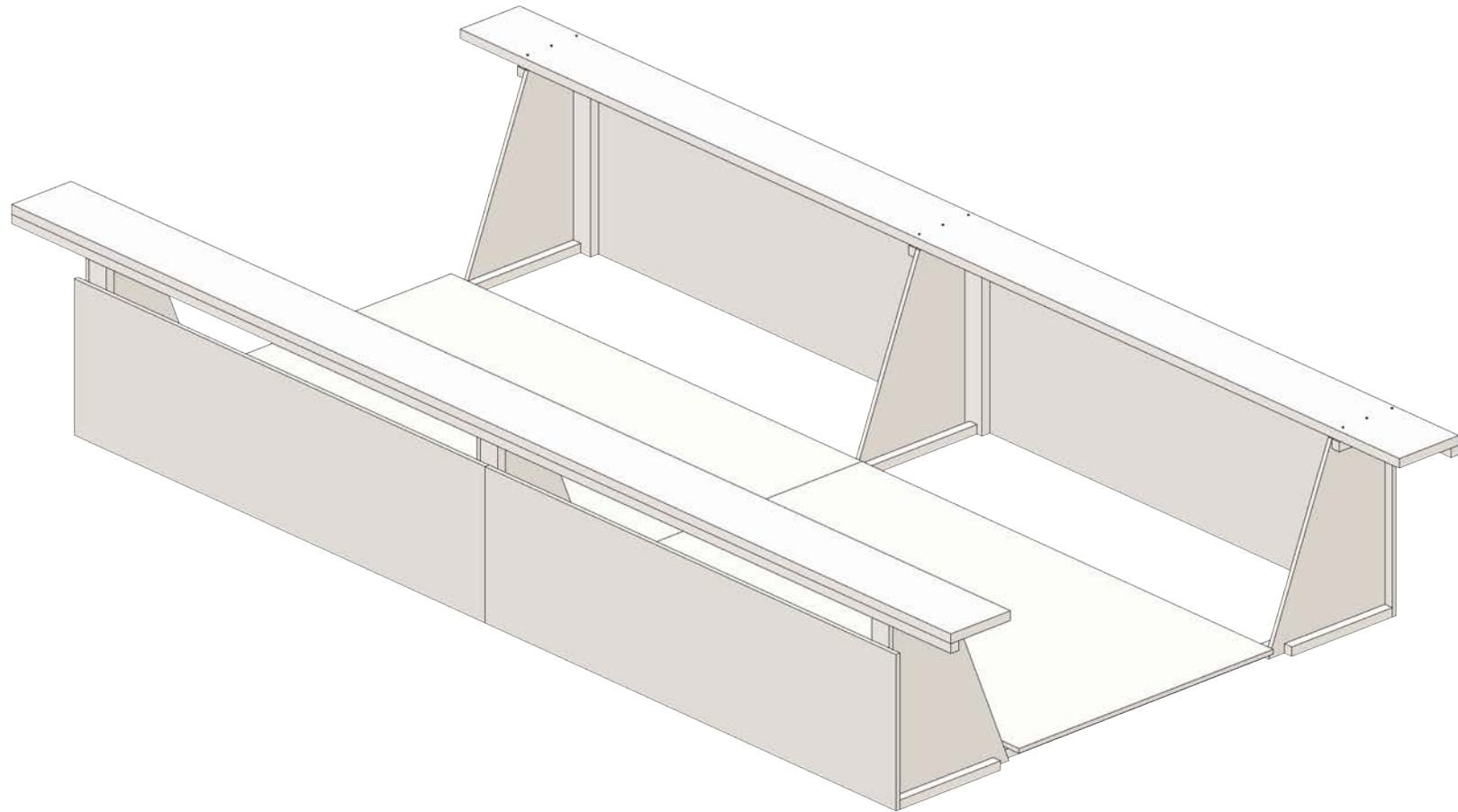

PARTS LIST:

- (5)- 4' X 8' X 3/4" OSB
- (2) 2 X 12 X 16'
- (1) 2 X 4 X 16' (RIP-IN-HALF)
- (3) 2 X 2 X 90" SPREADER BARS
- (6) 2 X 2 X 22" SUPPORTS
- (6) 2 X 2 X 10" SUPPORTS
- (6) 2 X 4 X 30" VERT SUPPORTS
- (8) 2 X 4 X 48" SLEEPERS

OSB CUT LIST

- (6) 3/4" OSB LEGS (CUT TO SHAPE)
- (4) 24" X 84" X 3/4" SIDE SUPPORT
- (2) 48 X 84" X 3/4" FLOOR

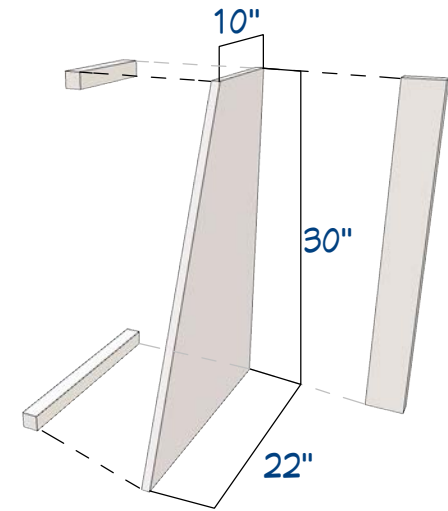

OSB LEG DETAIL

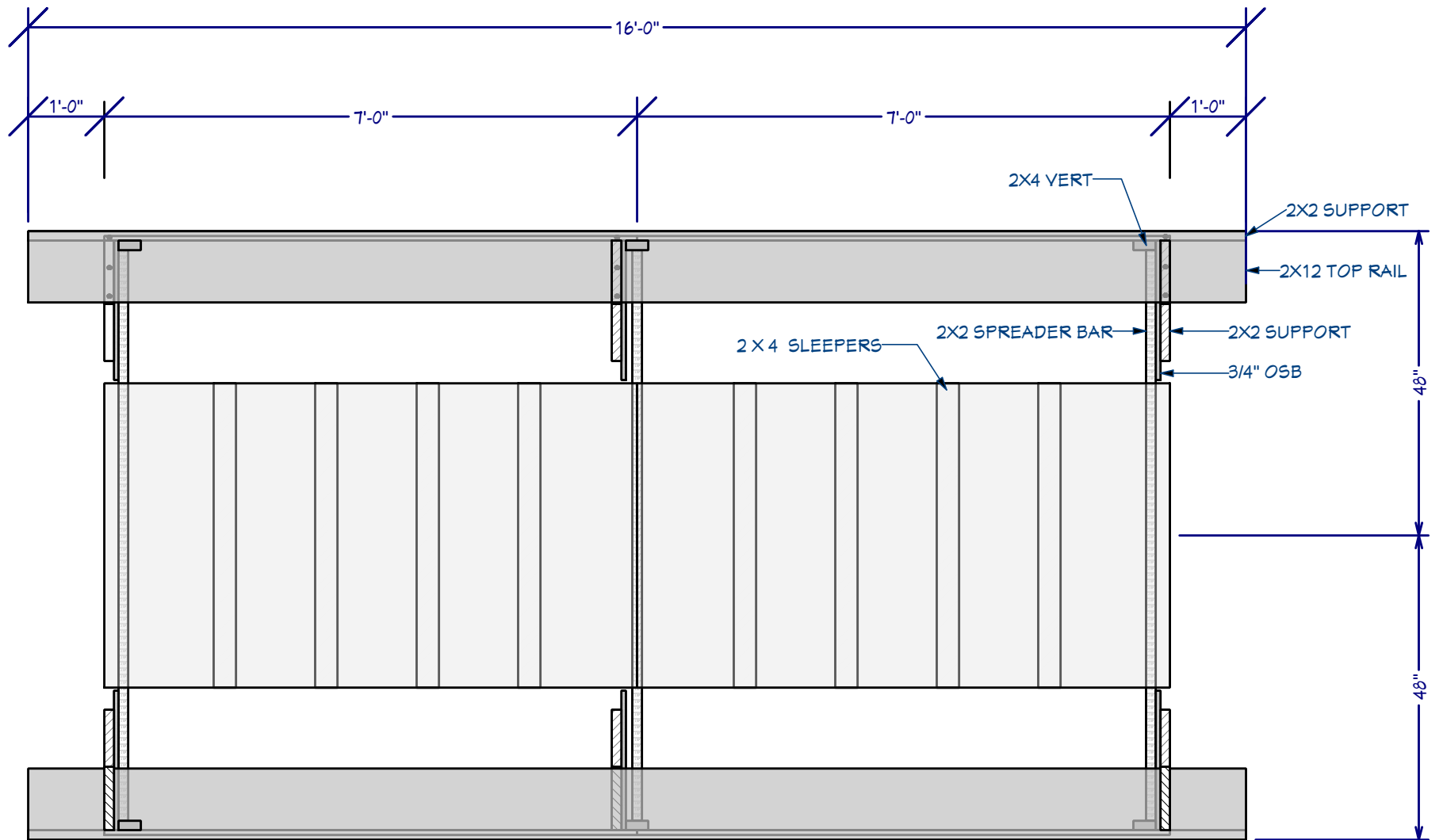

CNA Specialists
 1345 Encinitas Blvd.#404
 Encinitas, CA 92024
 858-354-8001
 paul@cnaspecialists.com

SCALE: 1/2"=1'-0"

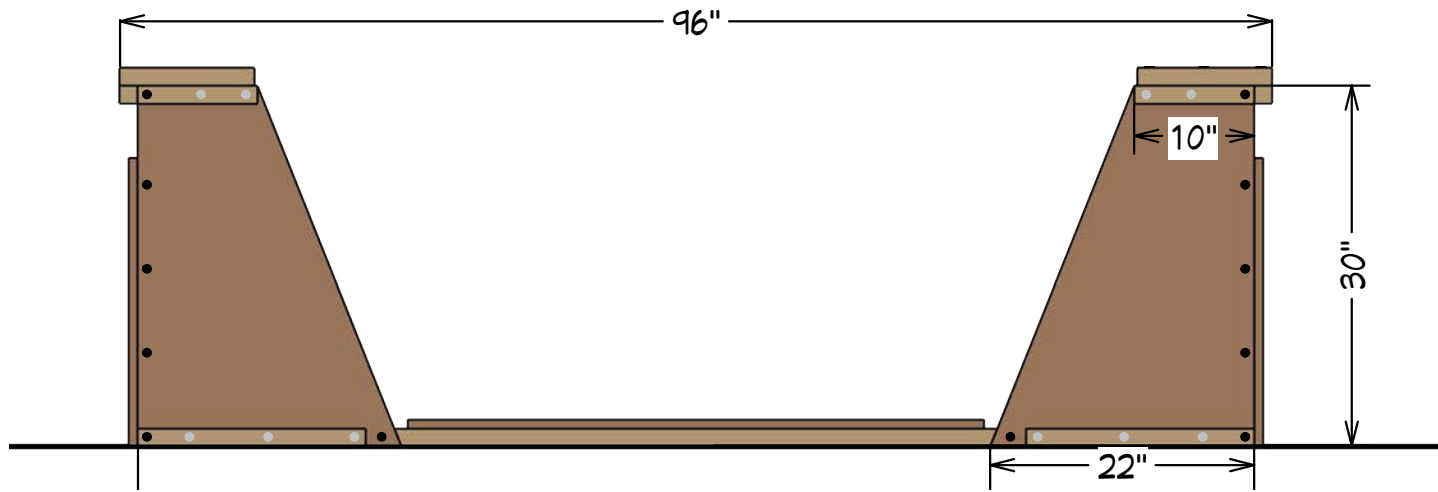

ELEVATION

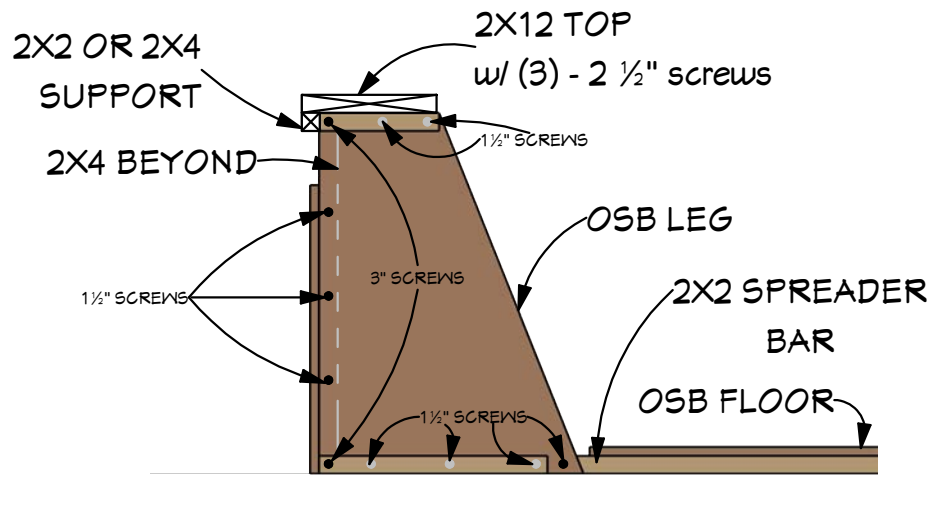

- SCREW FROM OUTSIDE
- SCREW FROM INSIDE

S1 DETAIL
SCALE: 3/4"=1'-0"

CNA Specialists
1345 Encinitas Blvd.#404
Encinitas, CA 92024
858-354-8001
paul@cna-specialists.com